

Performance of A Current-Fed Soft Switched Full-Bridge Boost Double Stage Converter Using ZVS PWM

S Nagma Anjum¹ G.Pavana Jyothi²

¹Dept. of EEE Dr.KV Subba Reddy College of Engineering for Women, Kurnool, A.P, India

¹Dept. of EEE Dr.KV Subba Reddy College of Engineering for Women, Kurnool, A.P, India

*Corresponding Author: S Nagma Anjum

ABSTRACT: This paper presents a current-fed full-bridge boost dc/ac/dc converter with transformer isolation operating without switching power dissipation. The output voltage is regulated by dc/ac converter control frequency changes with a constant turn-off time of transistors. The proposed converter is devoid of parasitic oscillations, as all of the parasitic capacitances and inductances are included in a resonant tank circuit. The main advantage of such systems is that they include a capacitive output filter, which is preferred in higher voltage applications. Moreover, it achieves ZCS for all active switches and zero-voltage switching (ZVS) operation for all diodes on high voltage side, which is an additional benefit. In this paper, the system operation is first explained, and the simulation results for optimal mode of operation and sub-optimal mode of operation are presented.

Keyword: Bridge, current-fed, dc/ac/dc converter, resonant.

I. INTRODUCTION

High voltage DC-AC-DC converters with an isolation transformer are used in different types of electronic applications such as battery chargers and dischargers, uninterruptible power systems, hybrid electric vehicles. In the case of the applications where low input voltages have to be converted to high output voltages, current-fed converters are used, whereas in the case of higher power applications, full bridge boost converters are usually a good choice.

However, the design of high voltage dc-dc converters is problematic because transformer parasitic elements can change the converter behavior. The transformer leakage inductance causes undesirable voltage spikes that may damage the circuit components, and the winding capacitance may result in current spikes. A vital factor that determines the size and the cost of a converter is its operation frequency. In order to minimize the size and the cost, the frequency has to be maximized. However, higher frequencies result in the increase of transistor switching losses, and thus, the converter's effectiveness is limited. For that reason, many solutions have been proposed to minimize converter switching losses. The most popular control method of bridge converters is pulse width modulation (PWM). It utilizes a phase-shift control technique with constant frequency operation. The fixed frequency phase-shift control enables the implementation of ZCS for all converter switches.

However, the switches must provide a reverse-voltage blocking capability. Thus, they have to be constructed by means of an MOSFET in series with reverse-voltage blocking diodes. The use of the diodes increases the component count and cost, although it also causes higher conduction losses. Another solution proposed to minimize converter switching losses is a PWM boost full-bridge converter, in which the leading switches realize ZCS under wide load range, and the lagging switches realize zero-voltage switching (ZVS) under any load. Likewise in this solution, the leading switches have to be connected in series with reverse-voltage blocking diodes. In addition, a circulating current, which is a result of the introduction of an additional auxiliary inductance (connected parallel with the primary winding of the transformer), is the source of extra conduction losses.

II. DOUBLE STAGE DC/AC/DC CONVERTER

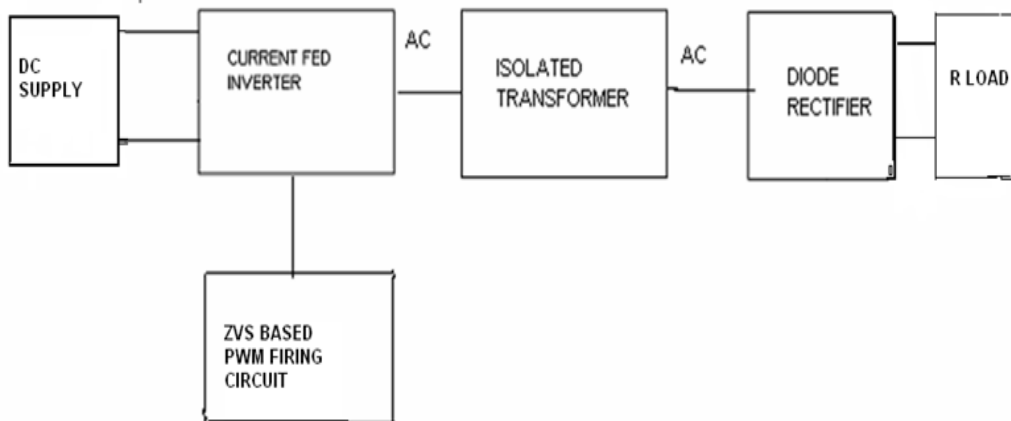

Fig.1: Block Diagram of Double Stage Dc/Ac/Dc Converter

In fig.1 DC supply is given to an Inverter. The Inverter converts the DC power into AC power. The DC input voltage is converted to AC in order to increase the efficiency of the converter. The boosting operation is done in the Inverter circuit, which is also a boost converter. Each Mosfet acts as a switch without any switching losses and facilitates the operation of the converter. Now the boosted voltage is further passed through an isolation transformer to isolate output from the input variations if any and also the input from the load variations. The isolation transformer is connected to the rectifier circuit on the other half, where the AC voltage is converted to the DC output voltage.

III. PROPOSED SYSTEM ARCHITECTURE AND DESCRIPTION:

The proposed converter system is devoid of parasitic oscillations as all the parasitic capacitances and inductances are included in the resonant tank circuit. The characteristic feature of resonant converters is that the transformer parasites do not disturb the circuit, because they are used as resonant circuit elements. In a current fed full bridge boost converter type the overlapping conduction time of the four converter switches is kept constant and the output voltage is regulated by varying the switching frequency. The conduction time is particularly calculated to ensure ZCS operation under a wide load range. MOSFET's and body diodes are used as the converter switches without the need for any additional diodes in series. The converter transistor turn-off time is constant and is equal to the time of the parallel connected capacitor overcharge. During the ZCS switch off-time, the L-C tank circuit resonates. This traverses the voltage across the switch from zero to its peak, and backdown again to zero. At this point the switch can be reactivated, and lossless zero voltage switching is facilitated. Therefore the switch transition losses go to zero regardless of operating frequency and input voltage. This could result in significant savings in power and improvement in efficiency. This feature of the converter makes it suitable for high frequency and high voltage converter design.

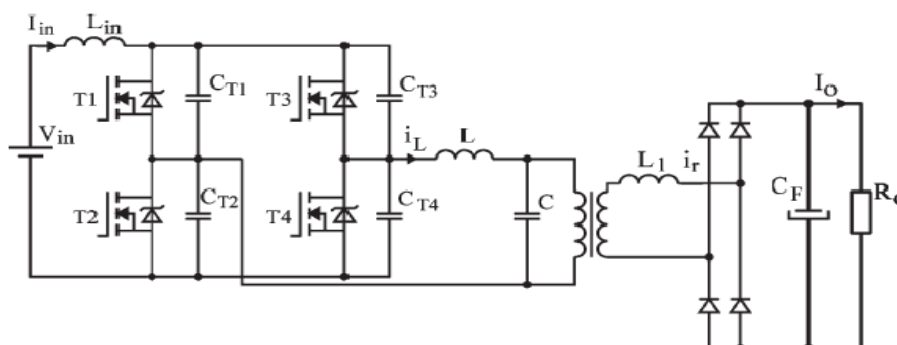
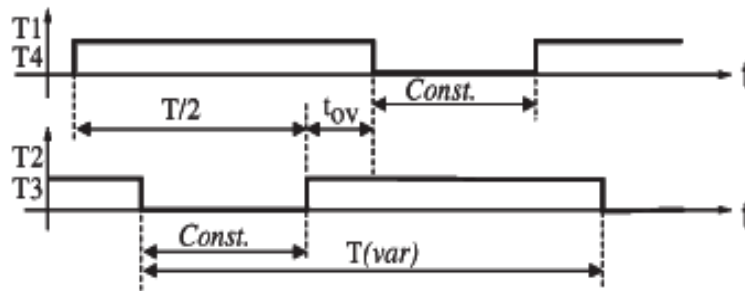

Fig.2. Proposed converter circuit a) Main circuit



b) Control pulse waveform

The proposed converter scheme is shown in Fig. 2(a). The inductance Ll represents the transformer leakage inductance, the capacitance C includes the transformer parasitic capacitance, and the capacitances CT include the transistor parasitic capacitances. The transistor control pulse waveforms are shown in Fig. 2(b). The converter is controlled by varying the switching frequency $f = 1/T$, while simultaneously keeping a constant break between the pulses. Thus, the transistor pulse overlap toV gradually decreases while the switching frequency increases. The maximal output voltage (power) is achieved in the minimal switching frequency, which is marked as nominal, i.e., f_n . For this frequency, the converter operates in the optimal operation point while its transistors are switched at zero-voltage and zero-current conditions. This optimal operation point is achieved by assuming the constant break between the control pulses depending on the resonant circuit elements and the load resistance nominal (minimal) value. In the optimal operation point, converter currents alternatively flow through transistors or its external capacitors CT . The transistor body diodes do not participate in current conduction. During one control period, the following subintervals can be determined: during the pulse overlap time toV , all the transistors are on, and because of the system symmetry, each of them conducts a half value of the input current, i.e., $I_{in}/2$, and a half value of the output current, i.e., $iL/2$. During the constant break between the control pulses, two transistors and two capacitors alternatively conduct $T1T4CT3CT2$ or $T2T3CT1CT4$. Because of the system symmetry, each transistor and each capacitor conducts, as in the previous subinterval, half values of the input and output currents. Thus, for the system mathematical analysis, there is no need to divide the entire switching cycle into particular subintervals. When the switching frequency increases above its nominal value or the load resistance increases above its nominal value, the converter goes to a suboptimal operation range. In the suboptimal operation state, the constant break between the control pulses is too long for the capacitors CT to overcharge. Thus, after the capacitor overcharge, an adequate transistor body diode takes over current conduction. After the body diode current falls to zero, it starts to increase in the transistor at zero voltage conditions. Based on the overlapping of pulses we can divide into two modes namely optimal and sub-optimal.

IV. OPTIMAL MODE OF OPERATION

Optimal mode of operation is a mode in which the converter will have lesser switching losses because of the application of phase shifted pulse width modulation strategy. The proposed soft switched full bridge boost DC/AC/DC converter is simulated in optimal operation mode analyzed at 250 kHz frequency

4.2. Design Specifications of Soft Switched Converter at $F_n=250\text{kHz}$

- $F_n = 250\text{KHz}$, $F_r=50\text{hz}$
- $L_{in}=1\text{e-}3\text{H}$
- $CT=7\text{e-}9\text{F}$
- $L=16\text{e-}6\text{H}$
- $C=29.73\text{e-}9\text{F}$
- $Ll=1.4\text{e-}6\text{H}$
- $Co=1\text{e-}5\text{F}$
- $R_{load}=100\text{W}$

4.3. Simulation Circuit for Current-Fed Soft Switched Full-Bridge Boost Dc/Ac/Dc Converter at $F_n=250\text{Khz}$

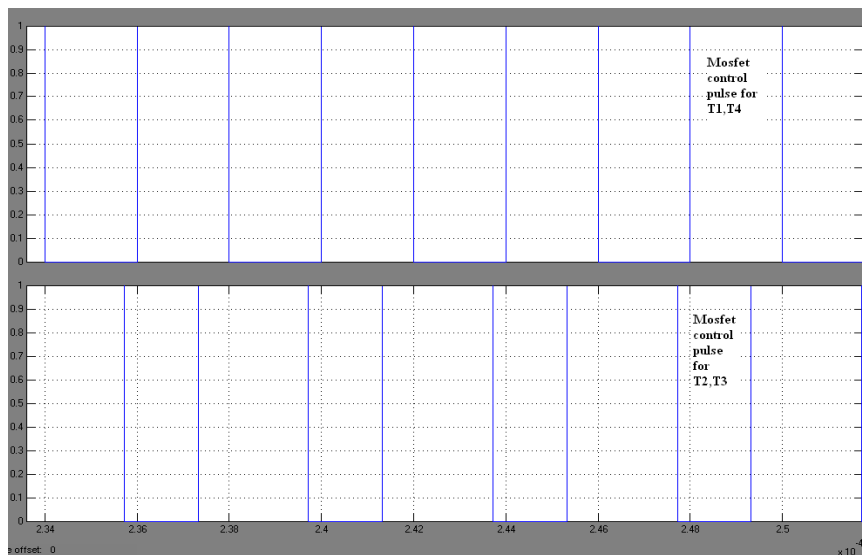
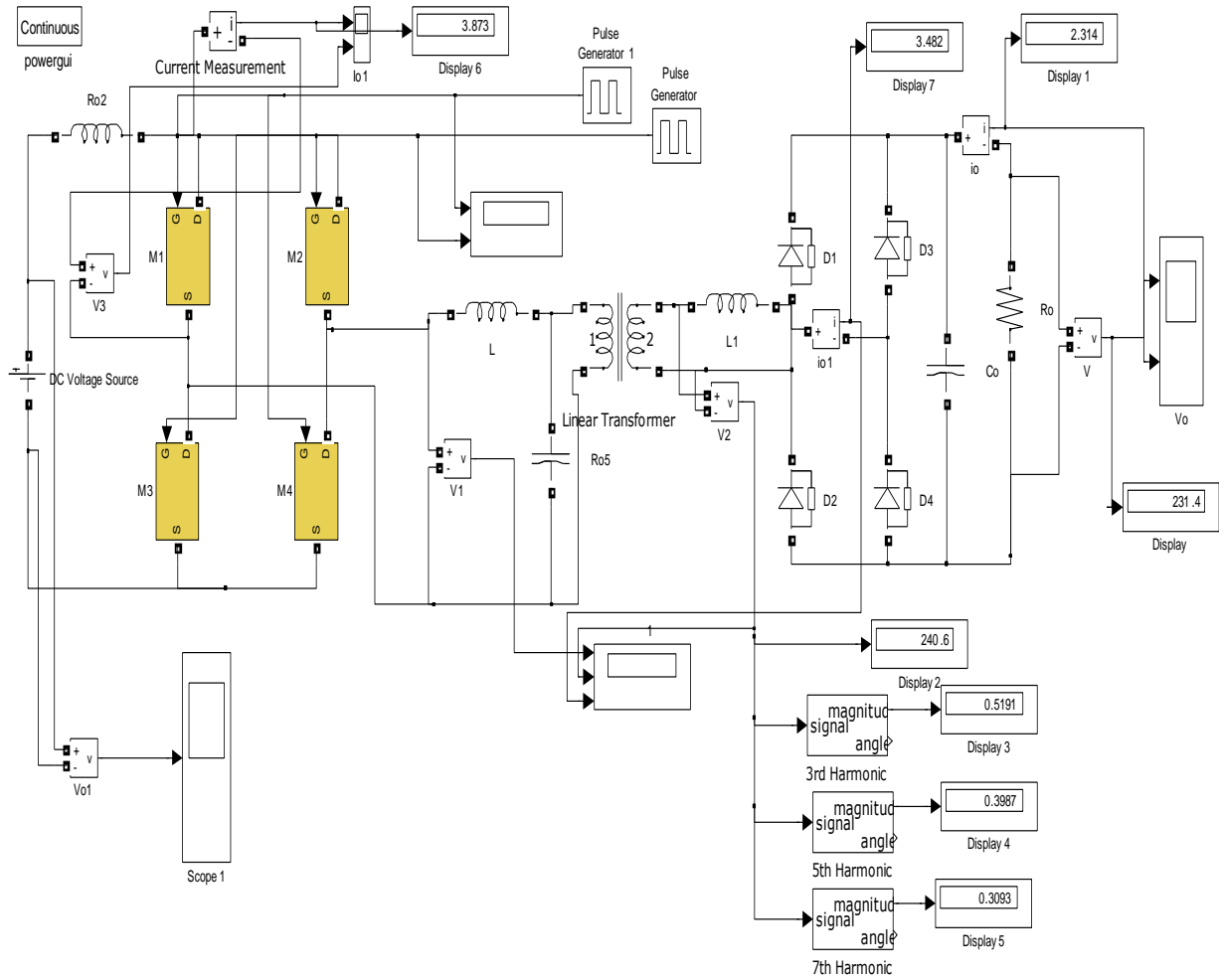

Fig.3.Pulses For MOSFETS

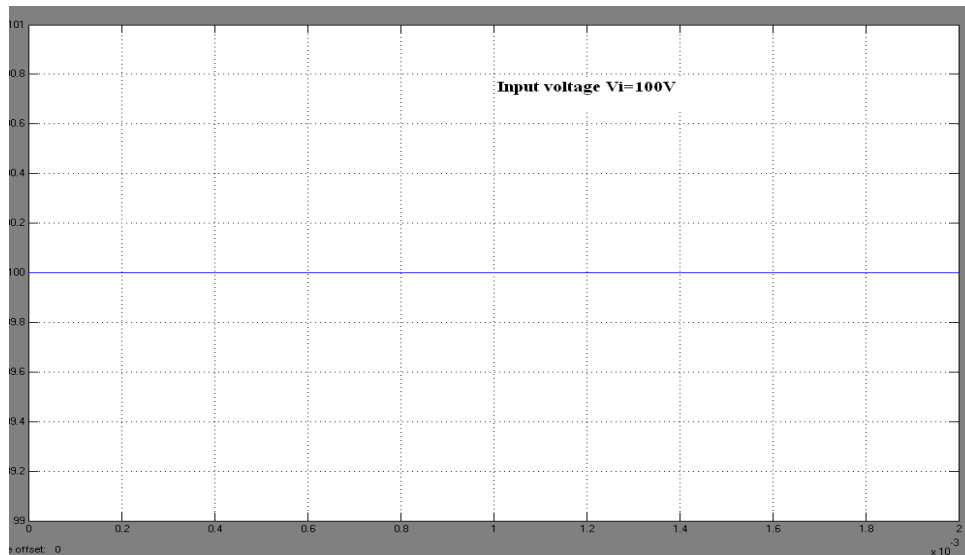

Fig.4.Input Voltage

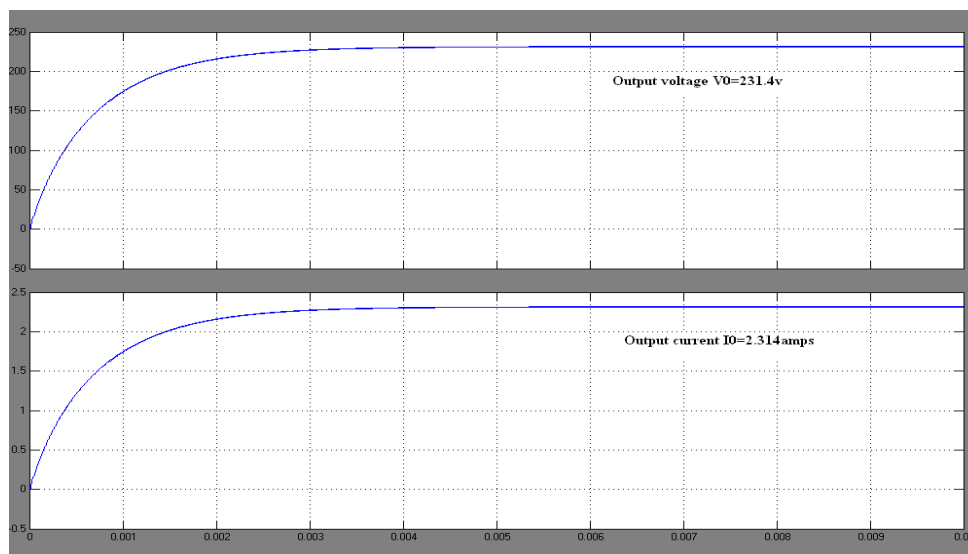

Fig.5.Output Voltage and Output Current

4.4. Performance Parameters Observed Of Current-Fed Full-Bridge Boost Dc/Ac/Dc Converter At $F_n=250$ Khz

- Input voltage $V_{in}=100V$
- Output voltage $V_{out}=231.4V$
- Output current= 2.314 amps
- $P_{out}=531.45W$
- Efficiency= 94.95%
- Switching loss= $28.47W$
- Voltage gain= $2.314V$

Input voltage is given as 100v. We get output voltage as 231.4v. Output voltage is increased by 131v compared to hard switching converter. So we can use this project where we need high power applications.

V. SUB-OPTIMAL OPERATION MODE

The switches are triggered with conventional triggering pulsed without overlap .Zero voltage switching will be achieved but the switch is triggered at of very instant of zero voltage crossing of switch voltage (capacitor) because there is no overlap provided. Soft switched converter is analyzed at 360 kHz frequency.

5.1. Design Specifications of Soft Switched Converter at $F_n=360\text{kHz}$

- $L_{in}=1\text{e-}3\text{H}$
- $C_T=7\text{e-}9\text{F}$
- $L=16\text{e-}6\text{H}$
- $C=14.33\text{e-}9\text{F}$
- $L_l=1.4\text{e-}6\text{H}$
- $C_o=1\text{e-}5\text{F}$
- $R_{load}=100\text{W}$
- $F_n=360\text{kHz}$
- $F_r=50\text{hz}$

5.2. Simulation Circuit Of Current-Fed Soft Switched Full-Bridge Boost Dc/Ac/Dc Converter At $F_n=360\text{ KHz}$

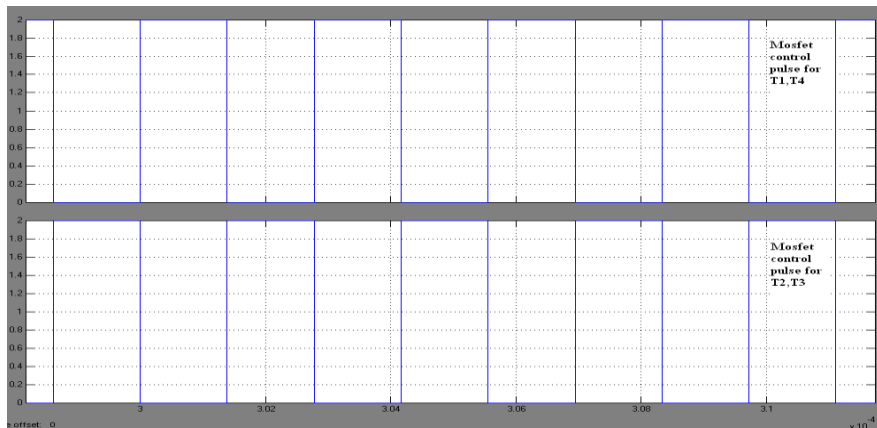
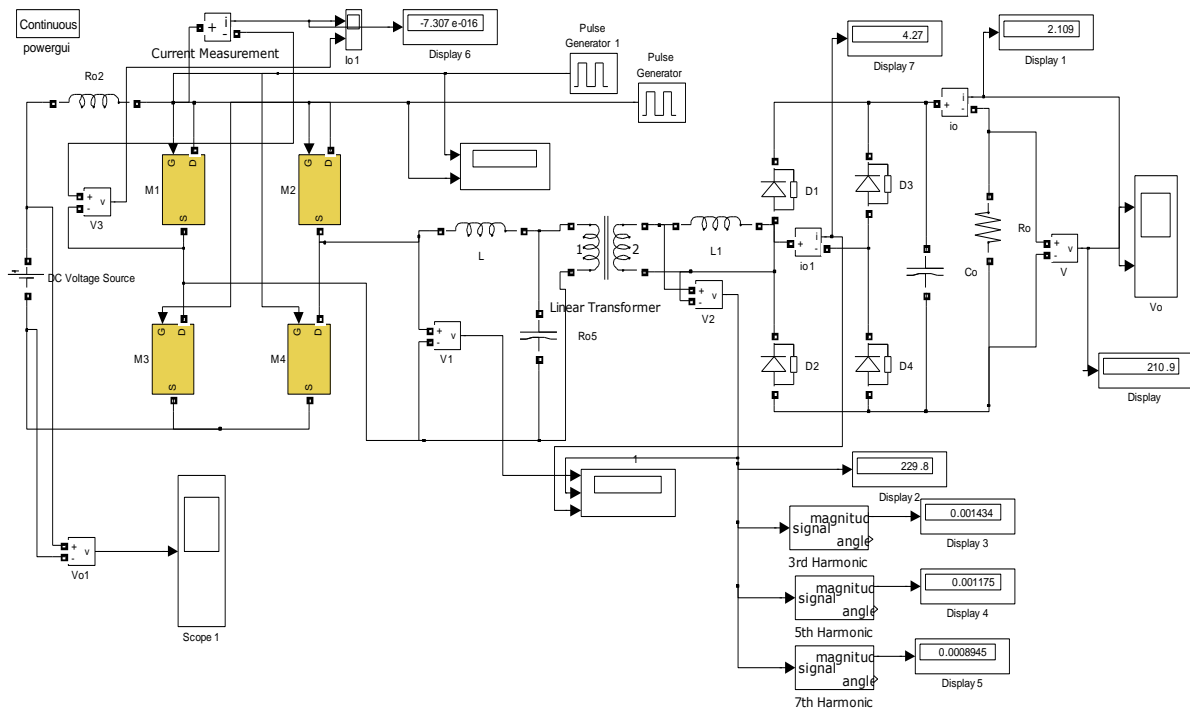

Fig.6.Pulses for MOSFETS

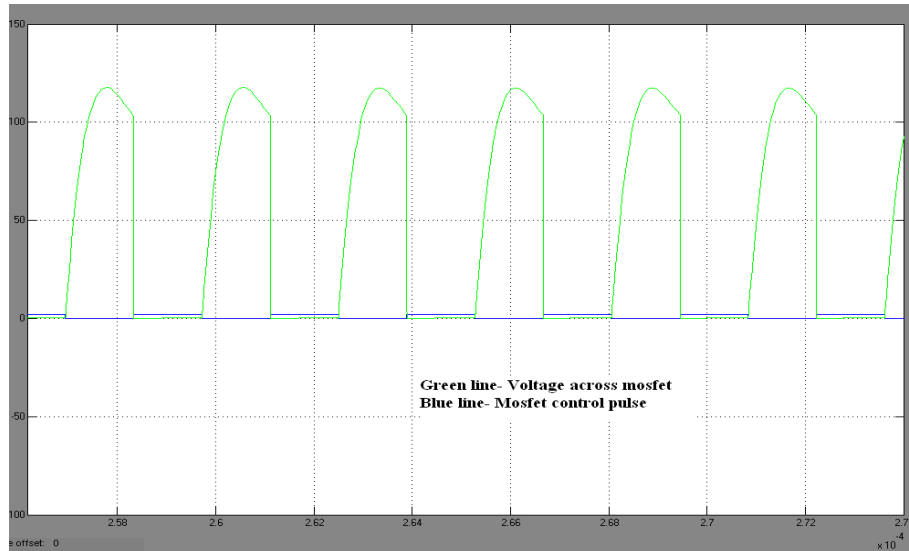

Fig.7.Voltage Across Switch- Condition Of Zero Voltage Switching

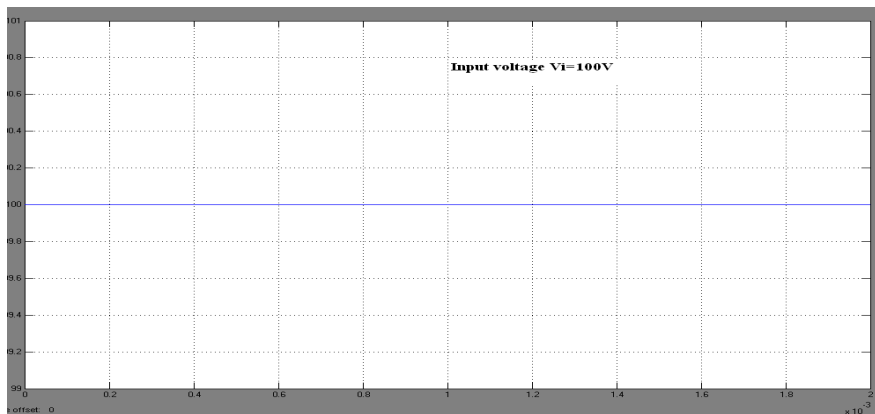

Fig.8.Input Voltage

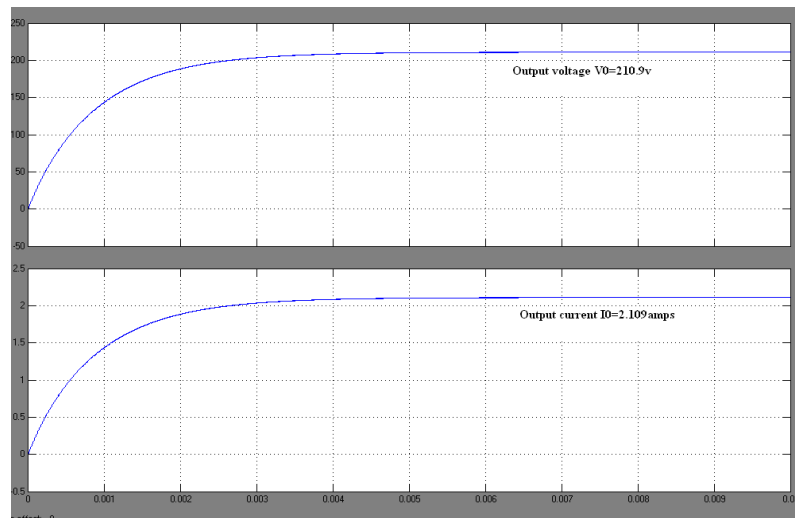

Fig.9.Output Voltage And Output Current

5.3. Performance Parameters Observed Of Current-Fed Full-Bridge Boost Dc/Ac/Dc Converter at $F_n=360$ KHz

- Input voltage $V_{in}=100V$
- Output voltage $V_{out}=210.9V$
- Output current=2.109 amps

- Pout=85.2W
- Efficiency=94.44%
- Switching loss=29.17W
- Voltage gain=2.109V

VI. CONCLUSION

In this paper current-fed full-bridge dc-ac-dc converter system with transformer isolation has been proposed. Detailed Matlab simulation results have been presented to evaluate the performance of the converter. The simulated and experimental values have shown. The dc/ac converter is controlled by varying the control frequency and the constant transistor turn-off time. During the whole control range, the transistor current and voltage waveforms do not overlap, so the switching power dissipations do not occur. The ac/dc rectifier diodes operate in discontinuous range so their switching power dissipations are also minimized. So a dc-ac-dc converter can be used for high power application which gives constant dc output voltage with fewer losses. The main features of the proposed converter are as follows

- 1) The primary benefit of using a Full-Bridge dc-dc converter is its power handling capabilities and stability.
- 2) The ac-dc rectifier diodes operate in discontinuous range with zero voltage switching so their switching power dissipations are also minimized.

REFERENCES

- [1]. R. Y. Chen, R. L. Lin, T. I. Liang, I. F. Chen, and K.C.Tseng, "Current fed full-bridge boost converter with zero current switching for high voltage applications," in Conf. Rec. IAS Annu. Meeting, 2005, vol. 3, pp. 2000–2006.
- [2]. C. Iannello, S. Luo, and I. Batarseh, "Full bridge ZCS PWM converter for high-voltage high-power applications," *IEEE Trans. Aerosp. Electron.Syst.*, [vol. 38, no. 2, pp. 515–526, Apr. 2002.
- [3]. L. Zhou and X. Ruan, "A zero-current and zero-voltage-switching PWM boost full-bridge converter," in Proc. IEEE PESC Conf., 2003, vol. 2, pp. 957–962.
- [4]. R. Watson and F. C. Lee, "A soft-switched, full-bridge boost converter employing an active-clamp circuit," in Proc. IEEE PESC Conf., 1996, pp. 1948–1954.
- [5]. K. Wang, L. Zhu, H. Odendaal, J. Lai, and F. C. Lee, "Design, implementation, and experimental results of bi-directional full-bridge DC/DC converter with unified soft-switching scheme and soft-starting capability"
- [6]. Belaguli and A. K. S. Bhat, "Operation of the LCC-type parallel resonant converter as a low harmonic rectifier," *IEEE Trans. Ind. Electron.*, vol. 46, no. 2, pp. 288–299, Apr. 1999
- [7]. Garcia, V., et al. "An optimized dc-to-dc converter topology for high-voltage pulse-load applications". (1994)
- [8]. Weinberg, A. H., and Schreuders, J. "A high-power high- voltage dc-dc converter for space applications". *IEEE Transactions on Power Electronics* (1986)
- [9]. Hino, H., et al "Resonant PWM inverter linked dc-dc converter using parasitic impedance of high-voltage transformer and its applications to X-ray generator". . (1988)
- [10]. Kim, Y. J., et al. "Comparative performance evaluations of high-voltage transformer parasitic parameter resonant inverter-linked high-power dc-dc converter with phase-shifted PWM scheme. . (1995).
- [11]. J.A.sabate, V.Vlatkovuc, R.B.Ridely, FC.Lee and B.L.Cho "design consideration for high voltage high power full bridge zero voltage switching PWM converters" in proc. Applied power electroics conf. and exposition (APEC '90) (1990)
- [12]. W.Chen, F.C.Lee, M.M.Jovanovic, J.ASabate, " A comparative study of class of full bridge zero-voltage-switched PWM converters," in proc. IEEE Applied Power Electronics Conf., (1995)